

Features:

- ▶ Maximum SPL Output 135 dB Peak
- ▶ 12" Differential Drive® low-frequency driver for low-distortion and higher SPL
- ▶ 1.5" diameter next generation JBL neodymium compression driver
- ▶ 1500W (dual 750 watt) highly efficient Class-D amplifier
- ▶ Optimized EQ for monitor or front-of-house applications
- ▶ Wireless remote control of its onboard DSP EQ parameters via Wi-Fi. Control and configure your show from anywhere.
- ▶ DSP input section, crossover, dynamic limiting, component optimization, selectable system EQ
- ▶ Professional XLR-1/4" combination inputs, RCA inputs, and XLR loop-through
- ▶ Integrated 36 mm pole mount socket with angle down tilt
- ▶ Integrated 12 x M10 suspension points
- ▶ Lightweight poplar plywood cabinets made structurally sound with tongue and groove joints and protected by JBL's tour proven DuraFlex™ finish

Application:

- ▶ PRX812 is a compact and versatile speaker in the PRX800 Series with remote Wi-Fi control of onboard DSP EQ parameters. It has been designed to deliver maximum performance for its weight and size as both a stage monitor and a front of house main PA. Two user selectable EQ settings are provided to optimize the system for either application. With a dual socket pole mount the PRX812 is a perfect match with a PRX818XLF subwoofer, offering a high performance self-powered sub/sat system.
- ▶ The PRX812 is comprised of a 12" Differential Drive® woofer, a 2408H-1, 37.5 mm (1.5 in) annular polymer diaphragm, neodymium compression driver mounted to a 90° by 50° horn, all driven by 1500 watt Class-D digital power amplifier. Sophisticated DSP is at the core of a fully featured input section, providing user selectable system EQ, protection, input sensitivity selection, cross-over functionality, dynamic limiting and discrete component optimization.
- ▶ All PRX800 cabinets are built from 18 mm, strong, light-weight poplar plywood made structurally sound with tongue and groove joints. All PRX800 Series cabinets are protected by JBL's tour proven DuraFlex™ finish. Grilles are made from dent-resistant 16 gauge steel and handles are made from light-weight glass-filled nylon for added strength and durability. All M10 suspension points are constructed from 14 gauge steel and have been tested with a yield-strength of 1000 lb each.
- ▶ The amplifier input panel offers XLR or ¼ inch jack compatibility and a sensitivity switch provides extra flexibility, making it possible to connect literally any sound source without using a mixer. Signal present and limiter lights indicate the system status and assist in setting the optimum level via the level control knob.



Specifications:

System:	
System Type:	Self Powered 12", two-way, bass-reflex
Maximum SPL Output:	135 dB peak
Frequency Range (-10 dB):	Main: 44.8 Hz – 20 kHz Monitor: 44.8 Hz – 20 kHz
Frequency Response (±3 dB):	Main: 55.7 Hz – 20 kHz Monitor: 56.5 Hz – 20 kHz
Input Connectors:	2 x Balanced XLR / 1/4 inch input, 2 x unbalanced RCA input
Input Impedance:	20K Ohms (balanced), 10K Ohms (unbalanced)
Signal Indicators:	Limit: Yellow LED indicates peak output has been reached and DSP limiter is acting Signal: Green LED indicates signal present Power: Blue indicates system has power and ready to pass audio
EQ:	User selectable presets for Main or Monitor position, Advanced EQ settings available using PRX Connect application via Wi-Fi
Dynamic Control (Input):	dbx Type IV™ limiter circuit
Crossover Frequency:	1.85 kHz
Amplifier:	
Design:	Highly efficient Class-D amplifier
Power Rating:	1500W (750W x 2)
AC Power Input:	100V - 240V ~ 50/60 Hz
Speaker:	
LF Driver:	1 x JBL 272G 305 mm (12 in) woofer
HF Driver:	1 x JBL 2408H-2 37.5 mm (1.5 in) annular polymer diaphragm, neodymium compression driver
Coverage Pattern:	90° x 50° nominal
Enclosure:	Asymmetrical, 18 mm, birch/poplar wooden enclosure
Suspension / Mounting:	Dual 36 mm pole socket, 12 x M10 Suspension Points
Transport:	1 x injection molded handle with backing cup
Finish:	Obsidian DuraFlex™ finish
Grille:	Powder coated, Obsidian, 16 gauge perforated steel with acoustically transparent black cloth backing.
Dimensions (H x W x D):	599 mm x 385 mm x 341 mm (23.6 in x 15.1 in x 13.4 in)
Net Weight:	18.1 kg (40 lb)
Gross Weight:	21.2 kg (48.0 lb)

JBL continually engages in research related to product improvement. Some materials, production methods and design refinements are introduced into existing products without notice as a routine expression of that philosophy. For this reason, any current JBL product may differ in some respect from its published description, but will always equal or exceed the original design specifications unless otherwise stated.

► PRX812 12" Two-Way Full-Range Main System/Floor Monitor

Frequency Response (Normal)

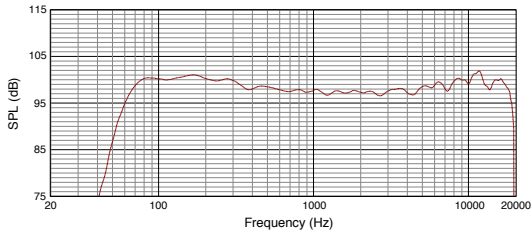

Frequency Response (Monitor)

Measurement performed in monitor position

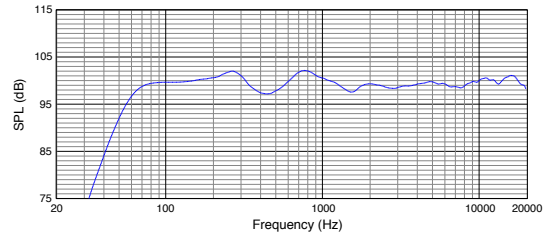

Block Diagram:

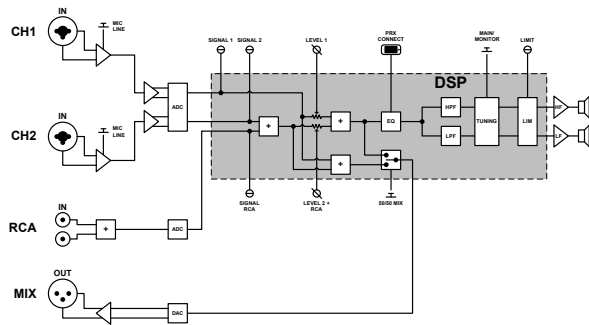

Dimensions

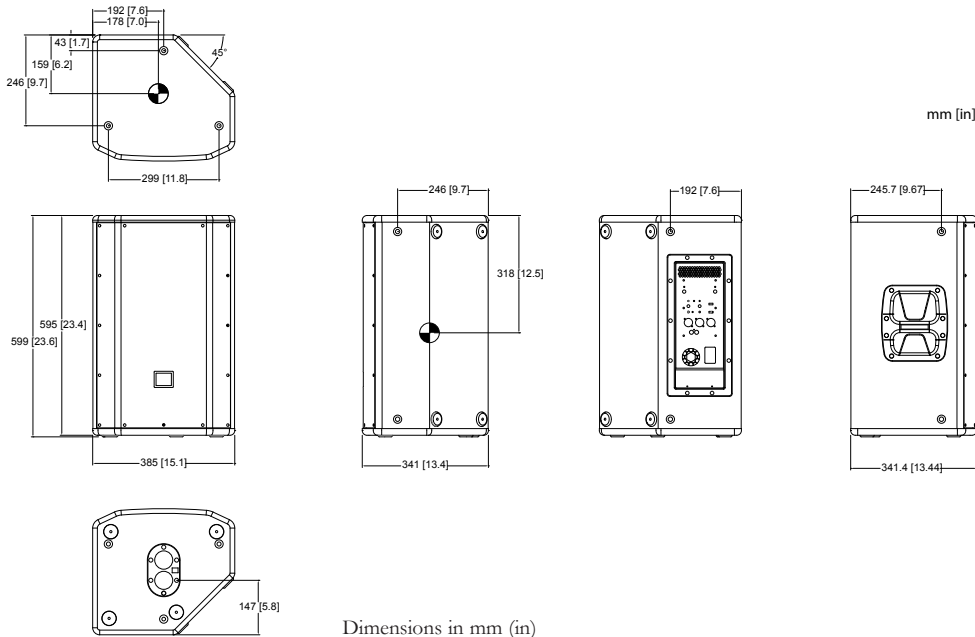

Dimensions in mm (in)



JBL Professional
 8500 Balboa Boulevard, P.O. Box 2200
 Northridge, California 91329 U.S.A.
 © Copyright 2017 JBL Professional
www.jblpro.com

PN: 5075804
 SS PRX812
 CRP
 06/17