

# BOYA

## UHF Wireless Microphone Series

UHF 无线麦克风系统

**BY-WM8 Pro**

**BY-WHM8 Pro**

**BY-WXLR8 Pro**

**RX-XLR8 Pro**

User Manual

用户手册



## Contents

<b>BY-WM8 Pro</b> .....	1
Configuration of the package .....	2
Product Structure .....	4
LCD Display Operation Guide .....	11
Connect Transmitters and Receiver .....	22
Set up the channel ,VOL, MONO mode .....	24
<b>BY-WXLR8 PRO</b> .....	27
Product Structure.....	28
LCD Display Operation Guide .....	30
Installing Batteries .....	31
Attach a microphone or a XLR cable .....	32
<b>BY-WHM8 PRO</b> .....	33
Product Structure.....	34
LCD Display Operation Guide .....	35
Installing Batteries .....	36
<b>RX-XLR8 Pro</b> .....	37
Product Structure.....	38
LCD Display Operation Guide .....	40
Installing Batteries .....	45
Troubleshooting .....	46
FCC STATEMENT .....	49
Specification .....	50
Frequency Chart .....	52

Thanks for choosing BOYA!

The BOYA BY-WM8 Pro system is an upgraded UHF dual-channel wireless microphone system for capturing audio with dual subjects, features an easy-to-read LCD display, a wide switching RF bandwidth, PLL-synthesized tuning and digital companding circuitry.

The package is suitable for a wide range of wireless applications such as interviews, electronic news gathering (ENG), electronic field productions (EFP), film production, business and educational applications, and more.

## **Features:**

- Ideal for interviews vlogging, podcasts, mobile journalism, electronic news gathering (ENG) and more
- Dual-Channel Wireless Receiver
- Excellent signal transfer and lower distortion
- 48 UHF Channels
- A or B two channel groups for transmitters and a receiver
- Selectable Stereo and Mono Mode
- Mic and Line-in
- Selectable Mute function
- Easy-to-read LCD displays
- Compact and hassle-free design
- Automatic LCD-locked Function
- Monitoring sound by headphone output (Receiver)
- Two AA batteries for both transmitter and receiver

The **BY-WM8 Pro-K1** consists of one body-pack transmitter(TX8 Pro), a portable receiver(RX8 Pro), and their accessories as following:



Portable receiver(RX8 Pro) (1)



Body-pack transmitters(TX8 Pro) (1)



Omni-directional lavalier microphone (x1)



Stereo 3.5mm mini plug cable



XLR output cable



Microphone Holder clip (x1)



Wind screen (x1)



Belt clip (x2)



Shoe mount adapter

The **BY-WM8 Pro-K2** consists of two body-pack transmitters(TX8 Pro), a portable receiver(RX8 Pro), and their accessories as following:



Portable receiver(RX8 Pro) (1)



Body-pack transmitters(TX8 Pro) (2)



Omni-directional lavalier microphone (x2)



Stereo 3.5mm mini plug cable



XLR output cable



Microphone Holder clip (x2)



Wind screen (x2)



Belt clip (x3)



Shoe mount adapter

## Transmitter A

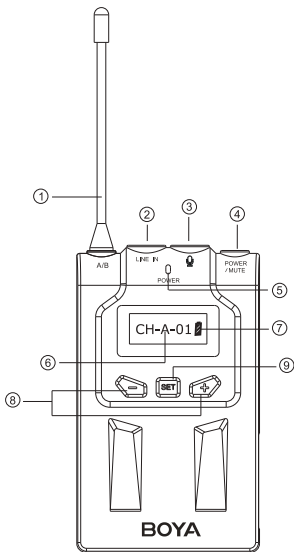

## Transmitter B

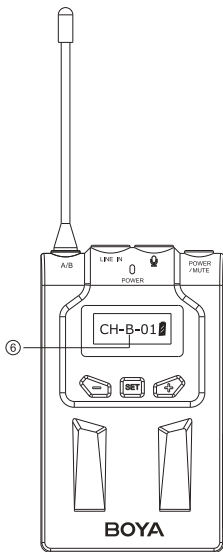

### 1. Antenna

### 2. Line In

### 3. Microphone input

Connect the supplied lavalier microphone here. Fully insert the microphone's 3.5mm plug and make sure it clicks into place, then lock the plug.

To remove, release the locking mechanism, then pull the plug out.

#### 4. Power/Mute button

- 1) Long press the power of the transmitter ON or OFF
- 2) Short press for muting

#### 5. Power LED

- 1) The power LED glows blue when the unit is on.
- 2) The power LED of transmitter glows red when low power.

For more details about LED indicator, please refer to as following:

Situation	Receiver	Transmitter A	Transmitter B
The transmitter and the receiver connects.	ANT-A and ANT-B Stay blue.	Stays blue	Stays blue
The transmitter A and the receiver connects; The transmitter B and the receiver disconnects.	ANT-A stays blue; ANT-B light off.	Stays blue	/
The transmitter A and the receiver disconnects; The transmitter B and the receiver connects.	ANT-A light off; ANT-B stays blue.	/	Stays blue
The transmitter and the receiver disconnects.	ANT-A and; ANT-B light off.	Stays blue	Stays blue

## 6. CH (Channel) indication

Shows the transmission channel.

**IMPORTANT:** Both two transmitters can be used for Transmitter A or Transmitter B.

How to exchange Transmitter A and Transmitter B, please kindly refer to Page 15.

## 7. Battery indication

Shows the battery condition



### NOTE

1. When the battery power icon is empty and blinking, the batteries are almost out of power, and you will need to change the batteries immediately.
2. The indicated battery condition may not be correct if the batteries were not new when installed. If you plan to use the component for a long period, it is recommended that you replace the batteries with brand new ones.

## 8. + (+ selection)/ - (- selection) buttons

Press these buttons to set the transmission channel, or attenuation level of the input signal.

For details, please see "How to set up channel ,VOL, STEREO and MONO" on page 24.



## 9. SET button

Press to change and enter display parameters.

For details, please see "How to set up channel, VOL, STEREO and MONO" on page 24.

## 10. Belt clip

## 11. 1/4" Thread

## 12. Battery compartment

Accommodates two AA batteries.

For more details, please see "Installing batteries" on page 16.

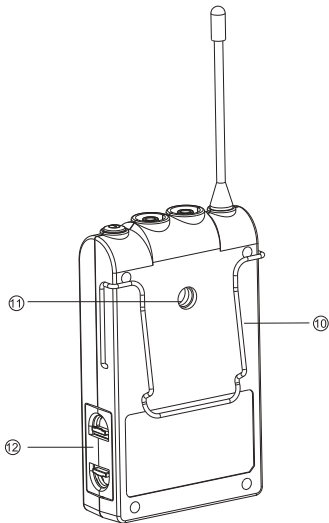

## Receiver

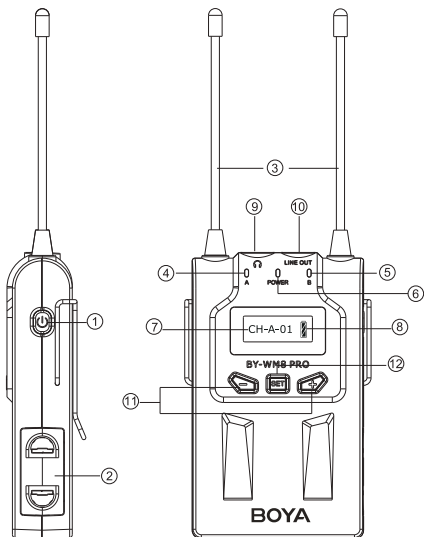

- 1. POWER OFF/ON**
- 2. Battery compartment**
- 3. Antenna**

#### **4. Power LED (ANT-A)**

#### **5. Power LED (ANT-B)**

#### **6. Power LED (POWER)**

- 1) The power LED glows blue when the unit is on.
- 2) The power LED of receiver glows red when low power.

#### **7. CH (Channel) indication**

Shows the transmission channel.

#### **8. Battery indication**

Shows the battery condition

#### **9. Monitor/ Earphone Connector**

(3.5mm diameter stereo mini jack)

To monitor the receiver output, connect the headphones to this connector.



#### **NOTE**

- Do not connect headphones with a monaural mini jack.
- This may lead to short-circuiting of the headphone output, resulting in distorted sound output.

#### **10. LINE OUT (audio output) connector (3.5mm diameter stereo mini jack)**

Connect one end of the supplied stereo 3.5mm mini plug-BMP conversion or XLR-BMP conversion output cable here, and the other end to the microphone input on a DSLR camera, camcorder, mixer, or amplifier etc.

### 11. + (+ selection)/ - (- selection) buttons

Press these buttons to set the transmission channel, attenuation level of the input signal, or "STEREO" and "MONO" mode.

### 12. SET button

### 13. Shoe mount adapter

For more details, please see "To attach the shoe mount adapter" on page 22.

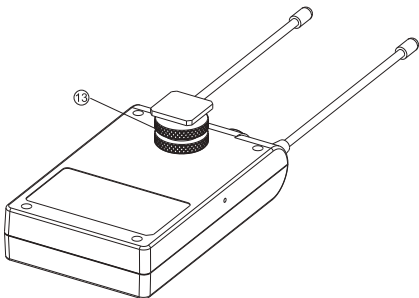

## LCD Display Operation Guide

### Receiver

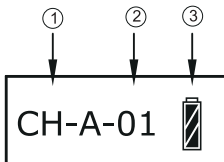

- ① Channel A
- ② Channel number (1-48)
- ③ Battery indication

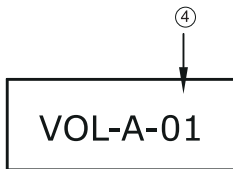

- ④ The volume of Channel A (1-31)

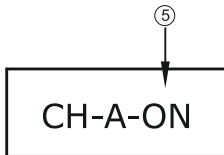

- ⑤ Press the +/- (+/- selection) button to OFF

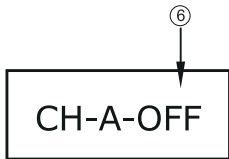

⑥ Press the +/- (+/- selection) button to ON

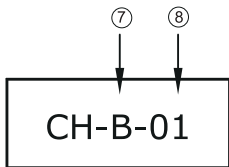

⑦ Channel B

⑧ Channel number (1-48)

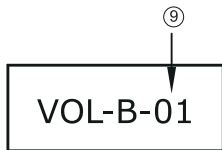

⑨ The volume of Channel B (1-31)

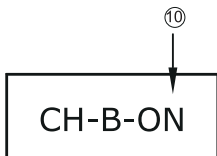

⑩ Channel B ON

Press the +/- (+/- selection) button to OFF

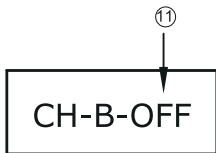

⑪ Channel B OFF

Press the +/- (+/- selection) button to ON

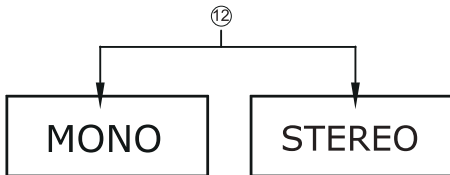

⑫ Press the +/- (+/- selection) button to MONO or STEREO

## How to set "MONO" and "STEREO"

1. Press "SET" button , the display section shows "MONO" .
2. Press the "+" or "-" (+/- selection) button, choose "MONO" and "STEREO" .

Important: The Mode that the factory set is "MONO".

The results are stored in memory, and the change becomes effectively when you turn on the transmitters next time.

	Transmitter A		Transmitter B	
Mode	Left Channel	Right Channel	Left Channel	Right Channel
MONO	√	√	√	√
STEREO	√			√

\* √=Available

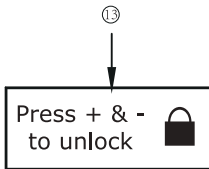

- ⑬ LCD will be locked automatically in 30 seconds  
Long press bottoms "+" and "-" to unlock.



## Transmitter

⑭ Mute On



⑮ Channel A

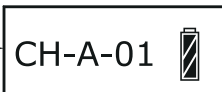

⑯ Channel B

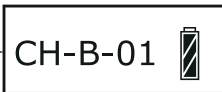

## How to change transmitters A and B

**Both two transmitters can be used with A or B.**

1. How to change transmitter A to transmitter B
  - 1) Set display section shows "CH-A-1".
  - 2) Long press "SET" bottom till display shows "CH-B-1".



Important: Set from any channel (1-48) is OK, for example, if display shows "CH-A-4", after long press "SET" bottom, it will show "CH-B-4"

2. How to change transmitter B to transmitter A, just redo the 1) and 2) steps as above.

## Installing Batteries

The transmitters and the receiver are each powered by two AA batteries. To install batteries, please follow these steps:

- 1. Turn OFF the units, Slide the battery-compartment catches inward (in the direction of the arrows “←,→”).**

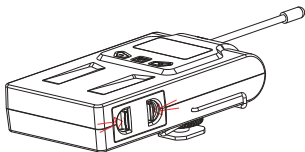

- 2. Take out the battery holder.**

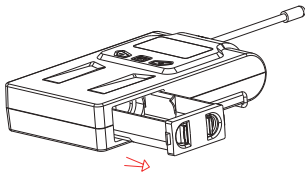

- 3. Insert the batteries into the battery compartment by matching their polarities to the indications inside the compartment. Then, set the battery holder in the original position.**

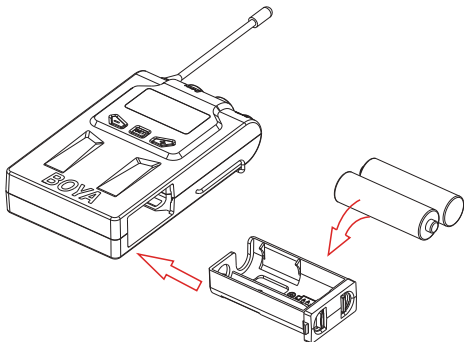

#### NOTE

Please make sure the units is turned OFF, because taking out the battery compartment during signal transmission may cause high noise.

#### **Battery indication**

When you turn the power on, the battery condition is shown by the BATT indication in the display section.  
Be sure to check the expiration date printed on the new batteries before using them.



## NOTE

- 1.The indicated battery condition may not be correct if the batteries were not new when installed. If you plan to use the units for a long period, it is recommended that you replace the batteries with brand new ones.
- 2.Insufficient battery power can decrease the ability of transmitters and receiver.  
Therefore, make sure your batteries start out with a full charge when using this system, and always carry spare batteries.

## Notes on battery

Batteries may leak or explode if mistreated.  
Be sure to follow these instructions:

- 1.Make sure install the batteries with correct polarity.
- 2.Always replace two batteries together.
- 3.Do not use different types of batteries or old and new one together.
- 4.When not using the components for a long period of time, remove the batteries to avoid leakage. If the batteries do leak, clean all leakage from the battery compartment and the component.

Leakage left in the compartment and the component may cause poor battery contact. If there seems to be poor battery contact, please consult our local dealer.



## CAUTION

Danger of explosion if battery is incorrectly replaced.  
Replace only with the same or equivalent type recommended by manufacturer.  
When you dispose of the battery, you must obey the law in the relative area or country.

## Attachment and Installation Procedures

### To attached the holder clip to the microphone

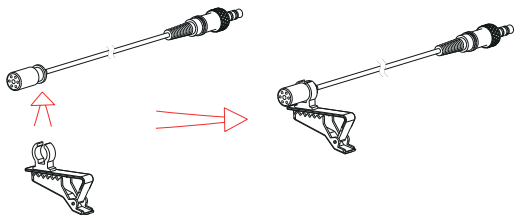

Push the holder clip against the bottom of the microphone until the holder clip clicks into place.

### To attach the wind screen to the microphone

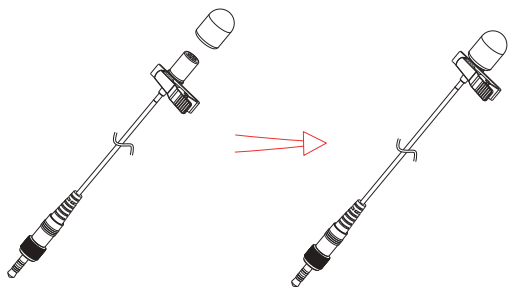

Insert the microphone into the hole at the bottom of the windscreen.

## Attaching the supplied accessories to the body-pack transmitter

### To attach the microphone

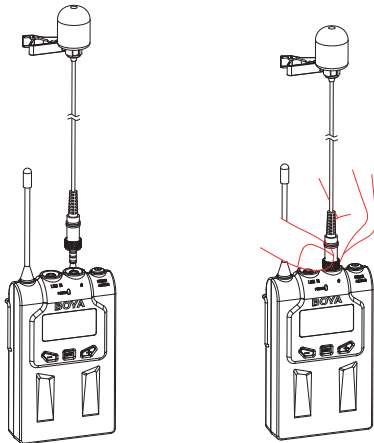

For a secure connection, be sure to turn and lock the connector cover.



#### NOTE

Make sure to attach or remove the microphone after turning off the transmitter.

For a secure connection, be sure to turn and lock the connector cover.

## To attach the belt clip

Before attaching the shoe mount adapter, attach the belt clip.

Reorienting the belt clip: The BY-WM8 Pro's belt clip can easily be removed and reattached to the body pack, so you can mount it upside down. To reorient the belt clip, please follow the below steps:

1. Push outward on the belt clip at one of the hinges, so one side of the clip pops out.
2. Push the belt clip out from the other hinge to completely remove the clip from the body pack.
3. Realign the belt clip with the body pack, making sure the clip is facing the desired direction.
4. Insert the two-way belt clip into the body pack, one hinge at a time.

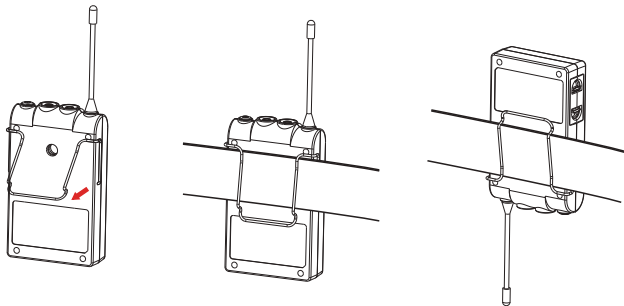

## To attach the shoe mount adapter

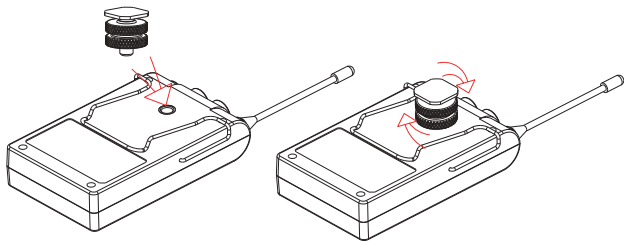

## Connecting the Transmitters and the Receiver

To connect the transmitters and the receiver, follow these steps:

1. Make sure the supplied lavalier microphones are connected to the transmitters' microphones input or plug a line-level source into the transmitters' line input.



### NOTE:

If you are connecting the receiver to a sound system, mute the sound system. Do not monitor with the headphones at the stage. Anytime you are changing the channel, remove your headphones and mute connected sound systems to avoid audible RF noise bursts.

2. Turn on the transmitters and the receiver.
3. Set the transmitters and the receiver to the same channel. If you are experiencing interference or noise on one channel, try a different channel.





## NOTE:

1. The Channel-A and Channel-B of receiver can be adjusted separately, when use two transmitters, transmitter A and transmitter B doesn't need to keep same channel.

Just need to keep Channel-A of receiver as same channel as Transmitter A, Channel-B of receiver as same channel as Transmitter B.

- Noted: 1) If you are using multiple BY-WM8 Pro wireless systems, make sure each system is set to a different channel, which can reduce the chance of intermodulation.
- 2) If the transmitters and the receiver connect, the power indicator stays blue. Otherwise, if the power indicator of receiver light off, that means, the transmitters and the receiver is disconnected.  
For more details, please kindly refer to page 5 .
  - 3) The results are stored in memory automatically. The stored channel number will appear in the display section in next time if you turn on the transmitters and the receiver.
4. With the headphone volume low, plug your headphones into the receiver and gradually raise the level to a comfortable volume for monitoring the transmission.
  5. The Channel and Volume of the Transmitters and the Receiver are "CH-1" and "VOL-28" when turn on them for the first time.
    - Adjust channel as you need.
    - Adjust as necessary to make sure an ample level is being transmitted to the receiver.The objective is to transmit the highest level without distortion for the best signal-to-noise ratio throughout the signal path.
  6. Once you have determined the transmission quality and level are good, mount the transmitter and the receiver.



## **NOTE**

1. When you are setting the transmission channel, the transmitter cannot be used to transmit signals.
2. Do not remove the batteries while setting the transmission channel.
3. Make sure that the selected channel is the same on the transmitters and receiver being used in the same system.

**For setting up the channel ,VOL, STEREO and MONO for receiver, please follow the below steps:**

### **Set up Channel**

#### 1) Set up Channel A

- Press "SET" button of Receiver, the display section shows "CH-A".
- Press the + (+ selection) button to increase the channel.
- Press the - (- selection) button to decrease the channel.
- Long press +/- buttons, the channel will increase and decrease automatically.

#### 2) Set up Channel B

- Press "SET" button of Receiver, the display section shows "CH-B"
- Press the + (+ selection) button to increase the channel.
- Press the - (- selection) button to decrease the channel.
- Long press +/- buttons, the channel will increase and decrease automatically.

## **Set up Volume**

### 1) Set up Channel A

- Press "SET" button of Receiver, the display section shows "VOL-A".
- Press the + (+ selection) button to increase the volume.
- Press the - (- selection) button to decrease the volume.
- Long press +/- buttons, the volume will increase and decrease automatically.

### 2) Set up Channel B

- Press "SET" button of Receiver, the display section shows "VOL-B".
- Press the + (+ selection) button to increase the volume.
- Press the - (- selection) button to decrease the volume.
- Long press +/- buttons, the volume will increase and decrease automatically.

## **Turn Channel A or B ON or OFF**

### 1) Set up Channel A

- Press "SET" button of Receiver, the display section shows "CH-A-ON" Or "CH-A-OFF".
- Press +/- buttons to OFF or ON.

### 2) Set up Channel B

- Press "SET" button of Receiver, the display section shows "CH-B-ON" Or "CH-B-OFF".
- Press +/- buttons to OFF or ON.



**NOTE:**

In order to save battery life, when you only use Transmitter A, please turn OFF Channel B of Receiver and vice versa.

**Set up "MONO" and "STEREO"**

For how to Set up "MONO" and "STEREO", please refer to page 14.

# BY-WXLR8 Pro

## Plug-on Transmitter

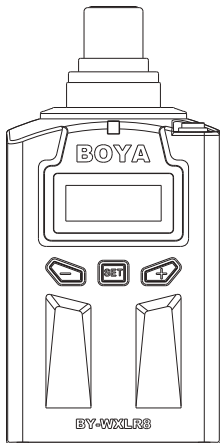

# Product Structure

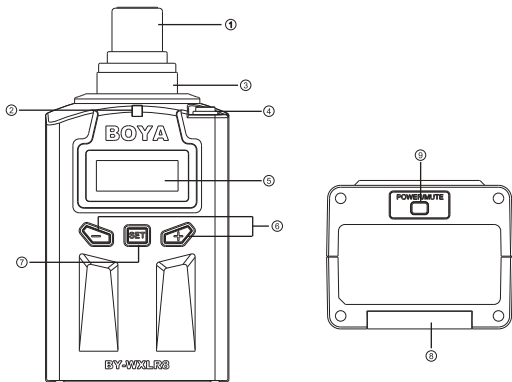

## 1. Audio XLR input connector

Connect a microphone or a line output connector of an audio mixer, etc.



### NOTE:

Only works with XLR dynamic microphones or battery-powered condenser microphones.

## 2. Power LED

1) The power LED glows blue when the unit is on.

2) The power LED of transmitter glows red when low power.

For more details about LED indicator, please refer to "Power LED" on page 30.

3) The power LED of BY-WXLR8 Pro blinks red when mute on.

### 3. Knurled ring

### 4. Line In



#### IMPORTANT

1. The BY-WXLR8 Pro does not support external power supply.
2. Do not set the INPUT mold to MIC mold while the audio signal is being input from the audio mixer, etc., it may cause excessive audio input, resulting in distorted playback or recorded sound or damage to playback or recording equipment.

### 5. LCD display

For more details, please refer to “LCD Display Operation Guide” on page 30.

### 6. + (+ selection)/ - (- selection) buttons

Press these buttons to set the transmission channel, or attenuation level of the input signal.

### 7. SET button

Press to change and enter display parameters.

For details, please see “How to set up channel, VOL, STEREO and MONO” on page 24.

### 8. Battery compartment

Accommodates two AA batteries.

### 9. Power/Mute button

Function	Operation
Power ON	Long press button
Power OFF	Long press button until it turns off
Mute ON	Short press button
Mute OFF	

## LCD Display Operation Guide.

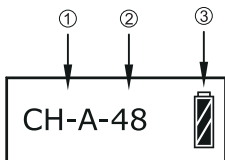

① Channel Group (A/B)

Long press "SET" button to change Channel "A" or "B"

② Channel number (1-48)

③ Battery indication

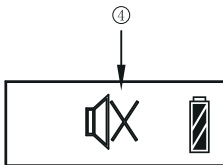

④ Mute On

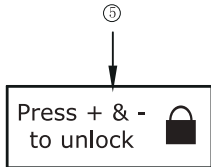

⑤ LCD will be locked automatically in 30 seconds

Long press bottoms "+" and "-" to unlock.



## Installing Batteries

The transmitter is each powered by two AA batteries. To install batteries, please follow these steps:

1. Slide the battery cover to release the lock and open the battery compartment.
2. Insert two new AA batteries into the battery compartment by matching their polarities to the indications inside the compartment, and then close the cover.

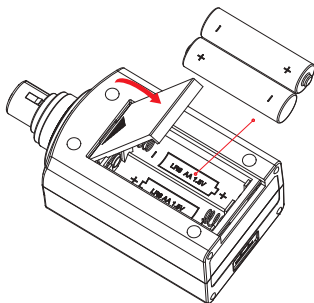
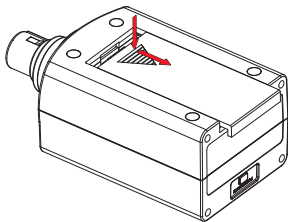

## To attach a microphone or a XLR cable

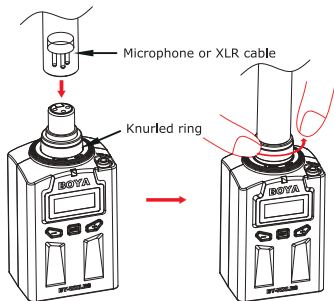

Push the microphone or cable connector into the XLR audio input jack of the BY-WXLR8 Pro, then turn the knurled ring in an anticlockwise direction, gently tightening it so the microphone or XLR cable base is seated firmly in place.

## To detach a microphone or a XLR cable

Turn the knurled ring in a clockwise direction, and pull off the microphone or cable slowly.



**Note:** Please turn off the transmitter before attaching or removing the microphone.

## Connecting the Plug-on Transmitter and the Receiver

To connect the Plug-on Transmitter and the receiver, follow these steps:

1. Turn on the transmitter and the receiver.
2. Set the plug-on transmitter and the receiver to the same channel.  
If you are experiencing interference or noise on one channel, try a different channel.

# BY-WHM8 Pro

Wireless Handheld Microphone

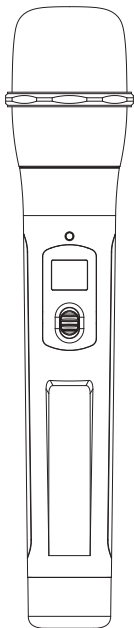

## Product Structure

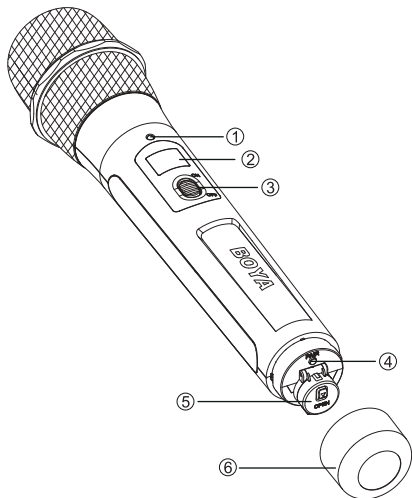

### 1. Power LED

### 2. LCD screen

For more details, please refer to "LCD Display Operation Guide" on page 35.

### 3. Power OFF/ON

## 4. PAIR

### A. How to change Channel

- 1) Short press "PAIR" button, the channel number blinks
- 2) Press "PAIR" button again to change channel.
- 3) Wait 3 seconds till channel number doesn't blink.

### B. Long press "PAIR" button to change Channel "A" or "B".

## 5. Battery compartment

## 6. Battery cover

### LCD Display Operation Guide

- ① Channel Group (A/B)  
Long press "SET" button to change Channel "A" or "B"
- ② Channel number (1-48)
- ③ Battery indication

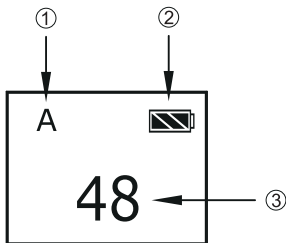

## Installing Batteries

The transmitter is each powered by two AA batteries. To install batteries, please follow these steps:

1. Turn the battery cover anti-clockwise to unscrew.
2. Push the "OPEN" bottom down.
3. Insert the batteries in the right polarity as shown.
4. Close the battery cover and retighten it by screwing clockwise until it is reasonably tight.

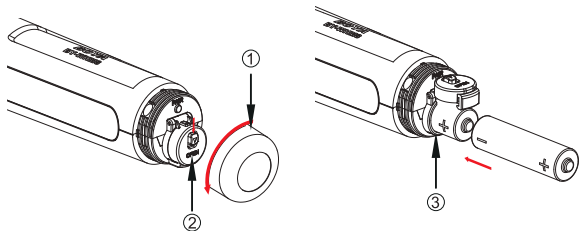

#### **NOTE:**

1. Please make sure the units is turned OFF, because taking out the battery compartment during signal transmission may cause high noise.
2. Please remove the batteries from the microphone when the microphone is not in use as current is drawn whenever a battery is installed.

#### **Connecting the wireless handheld microphone and the receiver**

To connect the wireless handheld microphone and the receiver, follow these steps:

1. Turn on the wireless handheld microphone and the receiver.
2. Set the wireless handheld microphone and the receiver to the same channel.  
If you are experiencing interference or noise on one channel, try a different channel.

# RX-XLR8 Pro

## XLR Plug-on Receiver

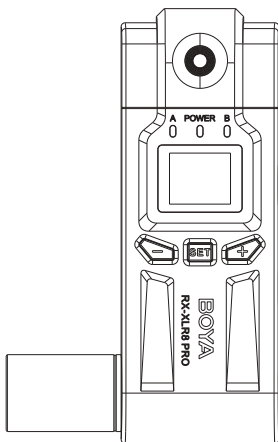

# Product Structure

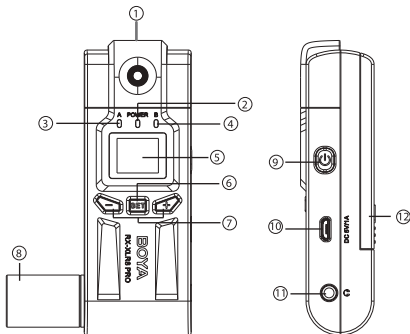

1. Antenna
2. Power LED

For more details about LED indicator, please refer to as following:

Situation	Receiver	Transmitter A	Transmitter B
The transmitter and the receiver connects.	ANT-A and ANT-B stay blue.	Stays blue	Stays blue
The transmitter A and the receiver connects; The transmitter B and the receiver disconnects.	ANT-A stays blue; ANT-B light off.	Stays blue	/
The transmitter A and the receiver disconnects; The transmitter B and the receiver connects.	ANT-A light off; ANT-B stays blue.	/	Stays blue
The transmitter and the receiver disconnects.	ANT-A and; ANT-B light off.	Stays blue	Stays blue



### 3. Power LED (ANT-A)

### 4. Power LED (ANT-B)

### 5. LCD screen

For more details, please refer to "LCD Display Operation Guide" on page 51.

### 6. SET button

### 7. + (+ selection)/ - (- selection) buttons

Press these buttons to set the transmission channel, attenuation level of the input signal, or "STEREO" and "MONO" mode.

### 8. Audio XLR output connector

Connect a microphone or a line output connector of an audio video camera, camcorder, mixer, etc.

### 9. POWER OFF/ON

### 10. Micro USB (DC 5V/1A)

### 11. Monitor/ Earphone Connector

(3.5mm diameter stereo mini jack)

To monitor the receiver output, connect the headphones to this connector.

### 12. Battery compartment

### 13. 3-pin XLR female to 3.5mm TRS audio output cable

### 14. Quick release stand adapter for XLR receiver

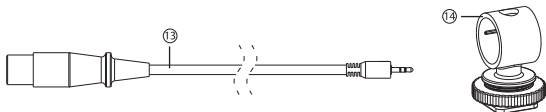

## LCD Display Operation Guide.

- ① A channel group indicator
- ② B channel group indicator
- ③ Battery indication

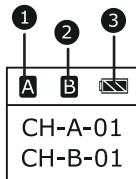

- ④ Channel A
- ⑤ Channel number (1-48)

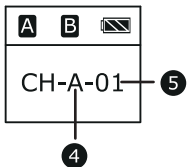

- ⑥ The volume of Channel A (1-31)

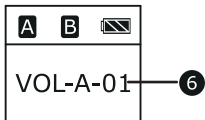

- ⑦ Press the +/- (+/- selection) button to ON

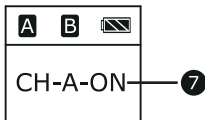

- ⑧ Press the +/- (+/- selection) button to OFF (Note: Before connecting with the transmitter, please make sure the receiver channel has been open.)

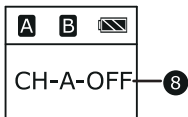

- ⑨ Channel B  
⑩ Channel number (1-48)

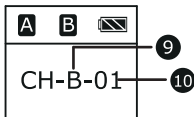

- ⑪ The volume of Channel B (1-31)

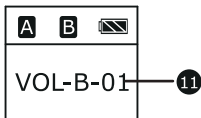

- ⑫ Press the +/- (+/- selection) button to ON

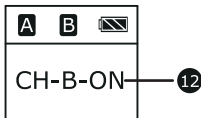

- ⑬ Press the +/- (+/- selection) button to OFF

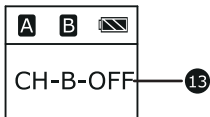

- ⑭ LCD will be locked automatically in 30 seconds Long press bottoms "+" and "-" to unlock.



## Installing Batteries

The transmitter is each powered by two AA batteries.

To install batteries, please follow these steps:

1. Slide the battery cover to open the battery compartment.
2. Insert two new AA batteries into the battery compartment by matching their polarities to the indications inside the compartment, and then close the cover.

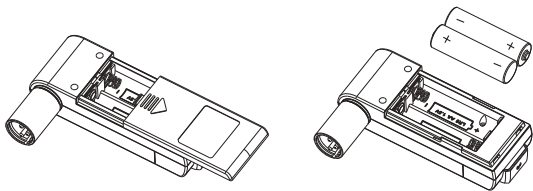

### NOTE:

1. Please make sure the units is turned OFF, because taking out the battery compartment during signal transmission may cause high noise.
2. Please remove the batteries from the receiver when the receiver is not in use as current is drawn whenever a battery is installed.

## Using the receiver with cameras, camcorders, audio recorders and other audio/video recording devices.

1. Using the BY-V01 dapter, mount receiver to cameras, camcorders, audio recorders and 3.5mm audio output of audio/video recording devices.
2. Using XLR to 3.5mm TRS cable, plug the 3.5 mm connector into the audio jack of your camera.
3. Insert earphone into receiver "🎧" to monitoring real-time sound if you need.
4. Long press the power ON/OFF button ("POWER" indicator lights blue)
  - Please make sure the antenna is oriented to the subject for the best transmission signal.

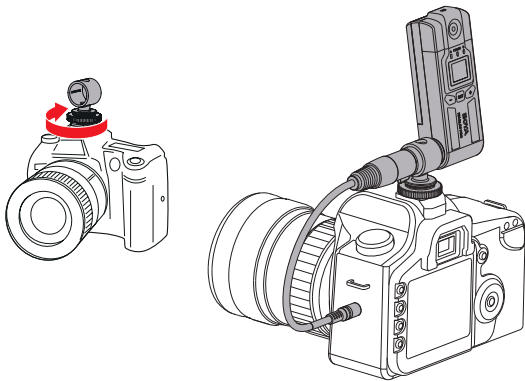

## Using the receiver with camcorders and other XLR recording devices.

1. Plug receiver to camcorders and other XLR audio/video recording devices with XLR output.
2. Insert earphone into receiver "🎧" to monitoring real-time sound if you need.
3. Long press the power ON/OFF button ("POWER" indicator lights blue)
  - Please make sure the antenna is oriented to the subject for the best transmission signal.

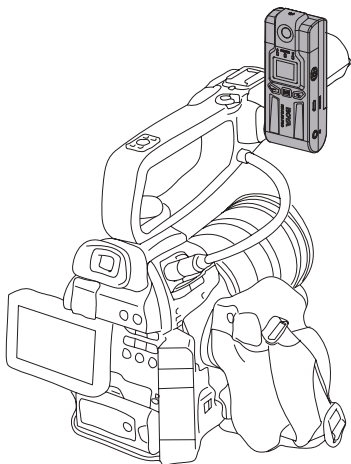

# Important Notes

## Usage and storage

- Operating the BY-WM8 Pro components near electrical equipment (motors, transformers, or dimmers) may cause it to be affected by electromagnetic induction.

Keep the BY-WM8 Pro components as far as from such equipment as possible.

- The presence of the lighting equipment may produce electrical interference over the entire frequency range. Position the BY-WM8 Pro components so that interference is minimized.
- To avoid degradation of the signal-to-noise ratio, DO NOT use the BY-WM8 Pro components in noisy

Places or in locations subject to vibration, such as the following:

- Near electrical equipment, such as motors, transformers, or dimmers.
- Near air condition equipment or places subject to direct air flow from an air conditioner.
- Near public address loudspeaker.
- Where adjacent equipment might knock against the receiver.

## Cleaning

Clean the surface and the connectors of the BY-WM8 Pro components with a dry, soft cloth. Never use thinner, benzene, alcohol or any other chemicals, since these may mar the finish.

## Troubleshooting

If you have any problem using the BY-WM8 Pro components, use the following checklist.

If any problem persists, please consult our local dealer, or contact us directly.

Symptom	Meanings	Remedy
The units does not turn on	The polarity orientation of the batteries in the battery compartment is incorrect.	Insert the batteries with the correct polarity orientation.
	The batteries are exhausted.	Replace the batteries with new ones.
	The battery terminals in the transmitter are dirty	Clean the + and - terminals with cotton swab.
The batteries become drained quickly.	The batteries are exhausted.	Replace the batteries with new ones.
	Manganese batteries are being used.	Use alkaline batteries. The battery life of a manganese battery is less than half that of an alkaline battery.
	The BY-WM8 Pro components is being used under cold conditions.	The batteries drain quickly under cold conditions.
The channel cannot be changed	An attempt was made to change the channel by pressing the SET button only.	Restart the unit, then change the channel with the + and - buttons.
There is no sound.	The channel setting on the transmitter is different from that on the receiver.	Use the same channel setting on both the transmitter and receiver.



The sound is weak.	The attenuation level on the transmitter is too high.	The input level of the transmitter is low. Press the button on the transmitter in attenuation level setting mode to decrease the attenuation level.
	The line input is selected on the transmitter.	Pull the cable out from LINE IN.
There is distortion in the sound	The attenuation level on the transmitter is too low.	The input level of the receiver is extremely high. Press the + button on the transmitter in attenuation level setting mode to increase the attenuation level.
There is distortion in the sound	The transmitter and the receiver are set to different channels.	Set the transmitter to the same channel.
	Headphones with a monoaural min jack is used.	Use the headphones with a stereo mini jack.
The audio is noisy or distorted. This can include drop outs, white noise, bursts, pops and clicks.	RF interference	<ul style="list-style-type: none"> <li>.Try a different channel. Make sure both units are on the same channel.</li> <li>.Try to position the antennas at a 45° angle in relation to each other. There can be a lot of RF interference outdoors.</li> <li>.Try moving indoors, where there is less RF interference.</li> <li>.Keep the units' antennas at least 2'(0.6m) away from conductive objects like metal and water.</li> <li>.Overhead telephone lines, fluorescent lighting, and metal fences can all cause interference.</li> <li>.Turn off all nearby computers and mobile phones.</li> </ul>

<p>The audio is noisy or distorted. This can include drop outs, white noise, bursts, pops and clicks.</p>	<p>RF signal is weak.</p>	<p>Make sure there is an unobstructed line of sight between the transmitter's and the receiver's antennas.          Keep in mind that your body, clothes, and onstage sets are possible obstructions.          Make sure the receiver and the transmitter are within 328'(100m) range.          If there are obstructions, you may need to move closer.</p>
	<p>The input level on the camera, recorder, or mixer is too high.</p>	<p>Turn down the audio input level on your camera or recording device. Lower the audio output level on the receiver.          Turn down the gain on your mixer. If there is no adjustment on the device, and the level is still high, adjust the microphone level on the transmitter. Keep this level as high as possible without distortion.</p>
<p>Too much ambience is being picked up.</p>	<p>When using an omnidirectional microphone like the one included with this system, the microphone may be picking up too much ambience.</p>	<p>Make sure the microphone is as close as to the subject as possible.</p>

## **FCC STATEMENT:**

This device complies with part 15 of the FCC Rules.

Operation is subject to the following two conditions:

- (1) This device may not cause harmful interference.
- (2) This device must accept any interference received, including interference that may cause undesired operation.

**Warning:** Changes or modifications to this unit not expressly approved by the party responsible for compliance could void the user's authority to operate the equipment.

**NOTE:** "This equipment has been tested and found to comply with the limits for a Class B digital device, pursuant to Part 15 of the FCC Rules.

These limits are designed to provide reasonable protection against harmful interference in a residential installation.

This equipment generates, uses and can radiate radio frequency energy and, if not installed and used in accordance with the instructions, may cause harmful interference to radio communications.

However, there is no guarantee that interference will not occur in a particular installation. If this equipment does cause harmful interference to radio or television reception, which can be determined by turning the equipment off and on, the user is encouraged to try to correct the interference by one or more of the following measures:

- Reorient or relocate the receiving antenna.
- Increase the separation between the equipment and receiver.
- Connect the equipment into an outlet on a circuit different from that to which the receiver is connected.
- Consult the dealer or an experienced radio/TV technician for help.

## **RF warning statement:**

The device has been evaluated to meet general RF exposure requirement. The device can be used in portable exposure condition without restriction.

# Specifications:

## System

Oscillator type:	PLL Synthesized Control Oscillator
Carrier Frequency Range:	556.71 MHz-575.98 MHz (Transmitter A) 576.39 MHz-595.66 MHz (Transmitter B)
Channels:	48
Frequency response:	40 Hz to 18 kHz (+/-3dB)
Operating temperature:	14° F to 122° F (-10°C to +50°C)
Storage temperature:	14° F to 131° F (-10°C to +55°C)

## TX8 PRO, BY-WXLR8 PRO, BY-WHM8 PRO, RX-XLR8 PRO

RF output power	≤10 mW
Antenna	1/4λ wire antenna
Spurious emission	250nW or less
Audio input connector	3.5mm jack
Reference audio input level	-60 dBV (MIC input, 0 dB attenuation)
Reference deviation	±5 kHz (-60 dBV, 1 kHz input)
Input frequency range	20Hz-20KHz
Distortion	0.5% or less
Power supply	Two AA size batteries SP-RX8 PRO/RX-XLR8 PRO: Two AA batteries or Micro USB (DC 5V)
Dimensions:	TX8 PRO:20.8 x 6.7 x 2.9 cm BY-WXLR8 PRO:5.7x4.55x11.69cm BY-WHM8 PRO: 5.3x5.3x25.6cm RX-XLR8 PRO: 10.74x6.74x2.68cm
Weight:	TX8 PRO:81g (without batteries) BY-WXLR8 PRO:162g (without batteries) BY-WHM8 PRO: 252g (without batteries) RX-XLR8 PRO: 73g(without batteries)

## Receiver:

Antenna	1/4 $\lambda$ wire antenna
Audio output connector	3.5mm jack
	RX-XLR8 PRO: XLR audio output
Signal to noise ratio	80dB or more
Distortion	0.5% or less
Headphone output level	30mW (16 $\Omega$ )
Audio output level	-60 dBV
Power supply	Two AA size batteries
Dimensions	208(H) $\times$ 67(W) $\times$ 29(L)mm
Weight	95g without batteries

## Lavalier Microphone

Transducer:	Back electret Condenser
Polar pattern:	Omni-directional
Frequency Range:	35Hz ~ 18 KHz
Signal / Noise:	74dB SPL
Sensitivity:	-30dB +/-3dB / 0dB=1V/Pa, 1 kHz
Connector:	3.5mm locking mini plug
Length:	1.2m (4')

# Frequency Chart

## Transmitter A

Channel(CH)	Frequency(MHz)	Channel(CH)	Frequency(MHz)
1	556.710	25	566.550
2	557.120	26	566.960
3	557.530	27	567.370
4	557.940	28	567.780
5	558.350	29	568.190
6	558.760	30	568.600
7	559.170	31	569.010
8	559.580	32	569.420
9	559.990	33	569.830
10	560.400	34	570.240
11	560.810	35	570.650
12	561.220	36	571.060
13	561.630	37	571.470
14	562.040	38	571.880
15	562.450	39	572.290
16	562.860	40	572.700
17	563.270	41	573.110
18	563.680	42	573.520
19	564.090	43	573.930
20	564.500	44	574.340
21	564.910	45	574.750
22	565.320	46	575.160
23	565.730	47	575.570
24	566.140	48	575.980

## Transmitter B

Channel(CH)	Frequency(MHz)	Channel(CH)	Frequency(MHz)
1	576.390	25	586.230
2	576.800	26	586.640
3	577.210	27	587.050
4	577.620	28	587.460
5	578.030	29	587.870
6	578.440	30	588.280
7	578.850	31	588.690
8	579.260	32	589.100
9	579.670	33	589.510
10	580.080	34	589.920
11	580.490	35	590.330
12	580.900	36	590.740
13	581.310	37	591.150
14	581.720	38	591.560
15	582.130	39	591.970
16	582.540	40	592.380
17	582.950	41	592.790
18	583.360	42	593.200
19	583.770	43	593.610
20	584.180	44	594.020
21	584.590	45	594.430
22	585.000	46	594.840
23	585.410	47	595.250
24	585.820	48	595.660

# 内容

概述.....	55
BY-WM8 Pro-K1内容.....	56
BY-WM8 Pro-K2内容.....	57
发射机的结构.....	58
接收机的结构.....	61
LCD显示屏操作指南.....	63
安装电池.....	67
附件.....	70
连接发射器和接收器.....	72
设置CH(频道)、VOL(音量)、将通道A / B设置为ON或OFF、 STEREO (立体声) 和MONO (单声道) .....	74
BY-WXLR8 Pro手雷发射机.....	76
BY-WHM8 Pro手持麦克风.....	80
RX-XLR8 Pro.....	83
产品结构.....	84
LCD显示屏操作指南.....	85
故障排除.....	90
FCC声明.....	92
规格.....	93
频率图.....	95



感谢您选择博雅！

BOYA BY-WM8 Pro是升级后的UHF双通道无线麦克风系统，它有简约易读的菜单，高品质的音质和稳定的性能。

该产品适用于各种无线应用如：采访、新闻访谈（ENG）、音频现场制作（EFP），电影制作，商业和教育等应用场景。

## 产品特点

- 双通道的无线接收器
- 48个UHF频道
- 可选立体声和单声道模式
- 可用作麦克风和音频传输
- 可选静音功能
- 简约易读的菜单
- 自动按键锁定功能
- 通过耳机监听输出声音（接收器）
- 连续操作超过6小时
- 操作范围可达100米（无障碍可达300米）
- 发射器和接收器由两节AA电池供电

BY-WM8 Pro-K1由一个腰包发射器 (TX8 PRO) 和一个便携式接收 (RX8 PRO) 及其附件组成清单如下:



便携式接收器 (RX8 Pro) (x1)



腰包发射器 (TX8 Pro) (x1)



全向型领夹式麦克风 (x1)



立体声3.5毫米迷你插头音频输出线 (x1)



卡农口音频输出线 (x1)



麦克风衣领夹子(x1)



防风棉 (x1)



腰包夹子 (x2)



冷靴座 (x1)

BY-WM8 Pro-K2由两个腰包发射器组成 (TX8 Pro) 和一个便携式接收器 (RX8 Pro) 及其配件组成清单如下:



便携式接收器 (RX8 Pro) (x1)



腰包发射器 (TX8 Pro) (x2)



全向型领夹式麦克风 (x2)



立体声3.5毫米迷你插头音频输出线 (x1)



卡农口音频输出线 (x1)



麦克风衣领夹子(x2)



防风棉 (x2)



腰包夹子 (x3)



冷靴座 (x1)

## 发射机A

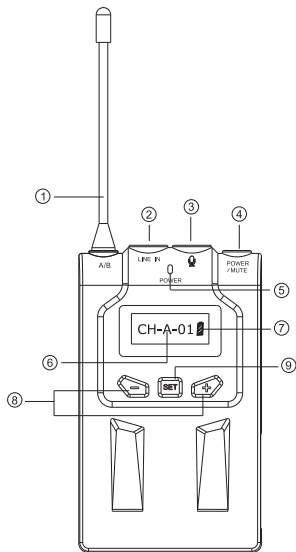

## 发射机B

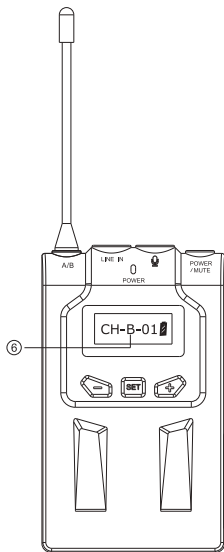

1. 天线
2. 音频输入
3. 麦克风输入

在此处插入附带的领夹式麦克风；完全插入麦克风的3.5毫米插头，确保它卡入到位，然后锁定插头。如要卸下，请松开锁定旋钮，然后拔出插头。

#### 4.电源/静音按钮

- 1) 长按开关的电源ON或OFF
- 2) 短按静音

#### 5.LED指示灯

- 1) 当设备开启时，LED指示灯呈蓝色亮起。
- 2) 电量低时，发射器的LED指示灯亮红光。

有关LED指示灯的更多详细信息，请参阅以下内容：

情况	接收器指示灯	发射器A	发射器B
发射器和接收器连接	ANT-A和ANT-B均亮蓝光	亮蓝光	亮蓝光
发射器A和接收器连接；发射器B和接收器断开连接。	ANT-A亮蓝光；ANT-B关闭	亮蓝光	/
发射器A和接收器断开；发射器B和接收器连接。	ANT-A灯关闭；ANT-B亮蓝光	/	亮蓝光
发射器和接收器断开连接	ANT-A和ANT-B均关闭	亮蓝光	亮蓝光

#### 6. CH (频道) 指示

显示传输频道

重要提示：两个发射器均可切换成发射器A或发射器B。

如何切换发射器A和发射器B，请参见第70页。

## 7.电量显示

### 显示用电情况



#### 注意

1.当电池电量图标为空并闪烁时，说明电池几乎没有电量，你需要马上更换电池。

2.如果安装时电池不是全新电池，电量指示可能不正确。

如果您打算长时间使用该麦克风，建议您更换全新的电池。

## 8. + (+选择) / - (-选择) 按钮

### 按这些按钮设置频道

有关详细信息，请参阅第77页的“如何设置CH(频道)、VOL(音量)、STEREO(立体声)和MONO(单声道)”

## 9. SET按钮

更改设置并输入显示参数。

有关详细信息，请参阅“如何设置CH(频道)、VOL(音量)、STEREO(立体声)和MONO(单声道)。”

## 10. 腰包夹

## 11. 1/4”螺丝口

## 12. 电池仓

可容纳两节AA电池。

有关详细信息，请参阅第70页的“安装电池”

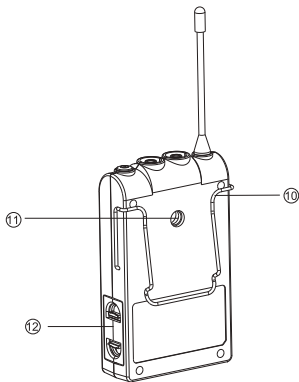

# 接收器

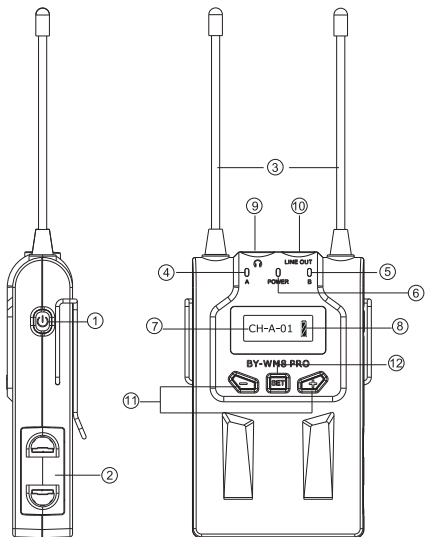

- 1.电源关OFF/开ON
- 2.电池仓
- 3.天线
- 4.LED指示灯 (ANT-A)
- 5.LED指示灯 (ANT-B)
- 6.LED指示灯 (电源)

- 1) 当设备开启时, 电源LED呈蓝色亮起。
- 2) 接收器的LED指示灯在电池电量低时发红光。

## 7. CH (频道) 指示

显示传输频道

## 8. 电池指示

显示电池电量

## 9. 监听孔/耳机连接

(3.5毫米立体声迷你插口)

要监听接收器输出音频，请将耳机连接至这个插口。



注意

- 请勿使用单声道耳机连接。
- 这可能会导致耳机输出短路，导致声音输出失真。

## 10. LINE OUT (音频输出) 接口

(3.5毫米立体声迷你插孔)

将提供的立体声3.5毫米迷你插头或卡农口音频插头的输出线的一端连接到此处，另一端连接到相机、便携式、摄像机、混音器或音响等的音频输入端。

## 11. + (+选择) / - (-选择) 按钮

按这些按钮设置频道或音量。

有关详细信息，请参阅第77页的“如何设置CH(频道)、VOL(音量)、STEREO(立体声)和MONO(单声道)。”

## 12. SET按钮

## 13. 冷靴座

有关详细信息，请参阅第74页的“安装冷靴座”。

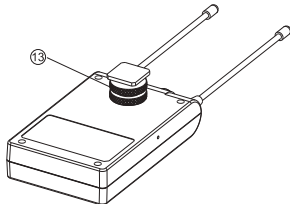



# LCD显示屏操作说明

## 接收器

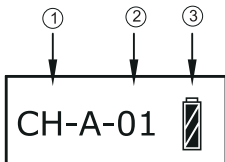

①通道A

②频道号码 (1-48)

③电池指示

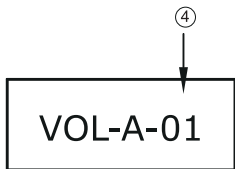

④通道A的音量 (1-31)

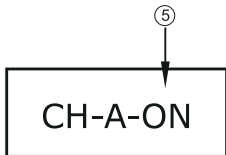

⑤通道A ON (开启)

可按+/- (+/-选择) 可按按钮至OFF (关闭)



⑥通道B OFF(关闭)

可按+/- (+/-选择) 可按钮至ON (开启)

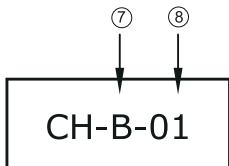

⑦通道B.

⑧频道号码 (1-48)

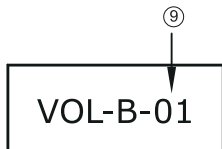

⑨通道B的音量 (1-31)

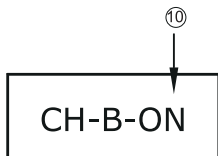

- ⑩通道B ON (开启)  
可按+/- (+/-选择) 按钮至OFF (关闭)

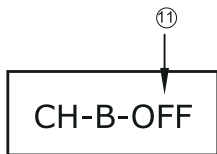

- ⑪通道B OFF (关闭)  
可按+/- (+/-选择) 按钮至ON(开启)

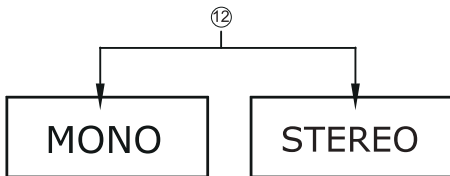

- ⑫按+/- (+/-选择) 按钮可转换MONO和STEREO

如何设置“MONO”和“STEREO”

- 1.按“SET”按钮，显示部分显示“MONO”。
- 2.按“+”或“-”（+/-选择）按钮，选择“MONO”或“STEREO”。

重要提示：出厂时的设置模式为“MONO”。

后续的设置会存储在内存中，下次打开发射器时，会与上次关闭时设置的模式一致。

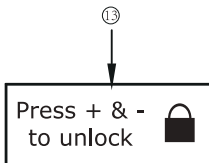

- ⑬ LCD将在30秒内自动锁定  
同时长按“+”和“-”按键解锁。

## 发射器

⑭ 静音



⑮ 通道A

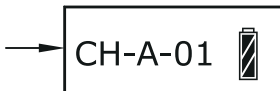

⑯ 通道B

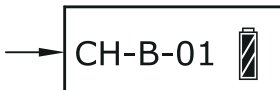

## 如何切换发射器A和B

这两个发射器可以切换成发射器A也可以切换成发射器B。

### 1. 如何将发射器A转换为发射器B

- 1) 设置显示的部分显示“CH-A-1”。
- 2) 长按“SET”键直到显示屏显示“CH-B-1”



注意：从任何频道（1-48）设置是可以的，例如，如果显示屏显示“CH-A-4”时，在长按“SET”键后，将显示“CH-B-4”。

2. 如何将发射器B转换为发射器 A，只需重做1) 和2) 步骤如上所述。

## 安装电池

发射机和接收器都由两个AA电池供电。要安装电池，请遵循以下步骤：

1. 打开电池舱，滑动电池舱向内（沿箭头方向，即“→,←”方向）

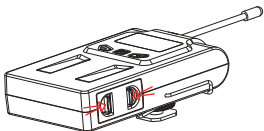

2. 取出电池舱

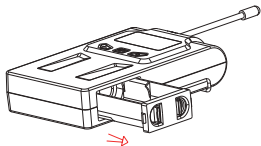

- 3.按电池舱内电池的极性与电池舱的指示安装，将电池插入电池舱内。然后将电池舱放回在原来的位置。

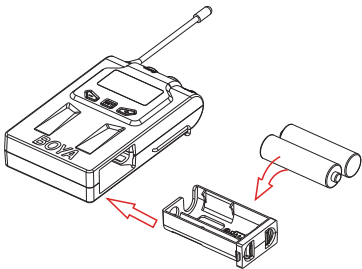

#### 注意

请确保麦克风关闭，因为在信号传输期间取出电池舱可能会导致高噪音。

### 电池指示

当您打开电源时，电池状态由显示屏中的电池指示显示。在使用新电池之前，务必检查打印电池的有效期。



#### 注意

- 1.如果安装时电池不是新电池，指示的电池状况可能不正确。如果您打算长时间使用本机，建议您更换全新的电池。
- 2.电池电量不足会降低发射器和接收器的功率。因此，使用本无线麦克风系统时，请确保电池完全充满电，并始终携带备用电池。

## 电池注意事项

如果处理不当，电池可能会泄漏或爆炸。请务必遵循以下说明：

1. 确保以正确的极性安装电池。
2. 更换电池时，直接更换两节电池。
3. 请勿使用不同类型的电池或新旧电池组合。
4. 如果长时间不使用麦克风，请取出电池以避免泄漏。  
如果电池漏液，请清洁电池舱和产品内的所有泄漏物。  
隔间中留有泄漏，可能导致电池接触不良。  
如果看起来电池接触不良，请咨询当地经销商。



### 警告

如果电池更换不当，可能会发生爆炸危险。建议使用制造商推荐的或与所推荐同等类型的电池。

处理电池时，必须遵守相关地区或国家/地区的法律。

## 安装附件

将领夹夹子安装到麦克风上

将领夹夹子推到麦克风的卡位上，直到领夹夹子卡入到位

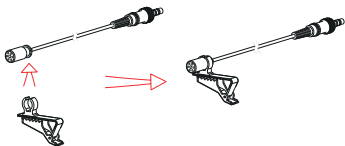

将防风棉安装到麦克风上

将麦克风插入防风棉底部的孔中。

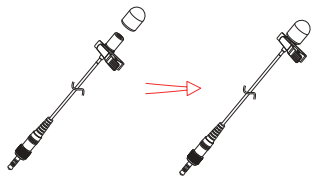

将附带的附件安装到腰包发射器上连接麦克风

为确保安全连接，请务必转动旋钮锁定连接器盖。



**注意**

关闭发射器后，务必安装或取下麦克风。要确保安全连接，请务必转动并锁定连接器盖。

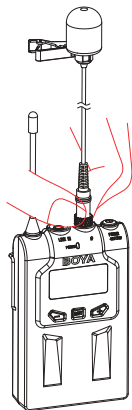



## 安装腰包夹子

在安装冷靴座之前，请先安装上腰包夹子

安装腰包夹子：BY-WM8 Pro的腰包夹子可以很容易地拆卸和重新安装到腰包发射器上，所以你可以把它颠倒过来。要安装腰包夹子，请按照以下步骤：

- 1.向外推动其中一侧的夹子，使夹子的一侧弹出。
- 2.将夹子从另一侧中推出，以完全从发射器中取出夹子。
- 3.将皮带夹与发射器中的孔对齐，确保夹子所朝的方向。
- 4.将夹子另一端插入腰包发射器中。

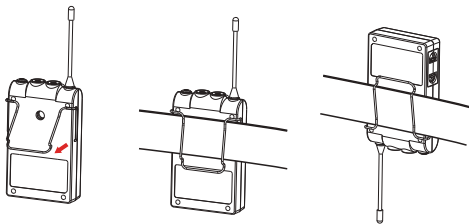

## 安装冷靴

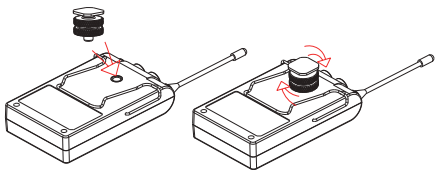

## 发射机与接收机的连接

连接发射机和接收机，请遵循以下步骤：

1. 确保所提供的领夹麦克风插入到发射机的麦克风插孔或将信号输出插头插入到发射机的线路输入中。



注意：

如果要接收器连接到音箱系统，请先将音箱系统静音，不要使用耳机进行监听。

更换频道时，请拔出监听耳机并将音箱系统静音，以避免发出噪声。

2. 打开发射器和接收器。
3. 将发射器和接收器设置为相同的频道。如果您在一个频道上遇到干扰或有噪音，可尝试切换成其他频道。



注意：

1. 接收器的通道A和通道B可以单独调节，当使用两个发射器时，发射器A和发射器B不需要保持相同的频道。

只需将接收器的CH-A设置为与发射器CH-A相同的频道，将接收器的CH-B设置为与发射器CH-B相同的频道即可。

### 注意：

- 1) 如果您使用多个BY-WM8 Pro无线系统，请确保将每个系统设置为不同的频道，这样可以减少互相干扰的可能性。
- 2) 如果发射器和接收器连接，则指示灯保持蓝色。反之，如果接收器的指示灯熄灭，则表示发射器和接收器断开连接。有关详细信息，请参阅第70页。
- 3) 设置结果会自动存储在内存中。如果再次打开发射器和接收器，频道、通道等信息会与上一次设置的一致。
4. 将耳机插入接收器监听，耳机音量较低时，可逐渐将音量调高到舒适音量以监听传输。
- 5.第一次打开时，发射器和接收器的通道和音量为“CH-1”和“VOL-28”。
  - 根据需要调整频道。
  - 根据需要进行调整音量，以确保将足够的电平传输到接收器。目标是在整个信号路径中传输最高级别而不失真，以获得最佳信噪比。
6. 确定传输质量良好后，安装发射器和接收器。



### 注意

- 1.当您设置传输通道时，发射器不能用于传输信号。
- 2.设置传输通道时请勿取出电池。
- 3.确保所设置的频道在同一通道中使用的发射器和接收器是相同的。

## 设置CH(频道)、VOL(音量)、STEREO (立体声)和MONO (单声道) 接收器, 请按照以下步骤:

### 设置频道

#### 1) 设置通道A.

- 按接收器的“SET”按键, 显示屏显示“CH-A”。
- 按+ (+选择) 按键上调频道。
- 按 - (-选择) 按键下调频道。
- 长按+/-按键, 通道将自动增减。

#### 2) 设置通道B.

- 按接收器的“SET”按键, 显示屏显示“CH-B”。
- 按+ (+选择) 按键上调频道。
- 按 - (-选择) 按键下调频道。
- 长按+/-按键, 通道将自动增减。

### 设置音量

#### 1) 设置通道A.

- 按接收器的“SET”按键, 显示部分显示“VOL-A”。
- 按+ (+选择) 按键增大音量。
- 按 - (-选择) 按键降低音量。
- 长按+/-按键, 音量将自动增加和减少。

## 2) 设置通道B.

- 按接收器的“SET”按键，显示部分显示“VOL-B”。
- 按+ (+选择) 按键增大音量。
- 按 - (-选择) 按键降低音量。
- 长按+/-按键，音量将自动增加和减少。

## 打开或关闭通道A或B

### 1) 设置通道A.

- 按接收器的“SET”按键，显示屏显示“CH-A-ON”或“CH-A-OFF”。
- 按+/-按键关闭或开启

### 2) 设置通道B.

- 按接收器的“SET”按键，显示屏显示“CH-B-ON”或“CH-B-OFF”。
- 按+/-按键关闭或开启



### 注意：

为了节省电量，当您只使用发射器A时，请关闭接收器的通道B，反之亦然。

## 设置“MONO (单声道)”和“STEREO (立体声)”

有关如何设置“MONO”和“STEREO”，请参阅第77页。

# BY-WXLR8 PRO 手雷发射机

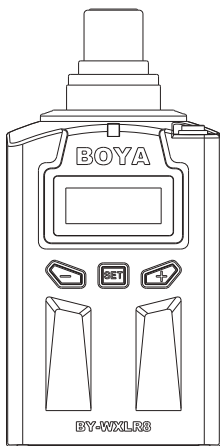

BY-WXLR8 PRO它可提供宽频率范围并覆盖48个无线通道，易于使用的功能包括：

BY-WXLR8 PRO可以连接XLR麦克风，并且可导入背景音乐或者其他设备的线路输出。它适用于便携式无线操作，适用范围广泛，例如单反相机的视频录制，广播电视，电子新闻采集等。

## 产品结构

- |           |                     |
|-----------|---------------------|
| 1. 卡侬插座   | 6. +(+)选择)/-(-选择)按钮 |
| 2. 指示灯    | 7. 音量切换键            |
| 3. 锁紧旋钮   | 8. 使用2节5号AA电池       |
| 4. 音频输入端口 | 9. 电源/静音按钮          |
| 5. 显示屏幕   |                     |

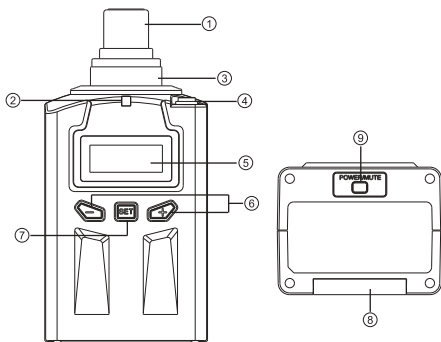

## 安装设置

1. 按竖箭头方向往下压，同时向横箭头方向往后推动电池盖。

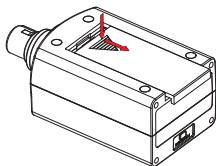

2. 按竖箭头方向旋转打开电池盖，如图装入2节LR6(规格AA)

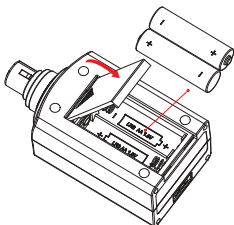

3. 按竖箭头方向将麦克风插入手雷卡侬母座。

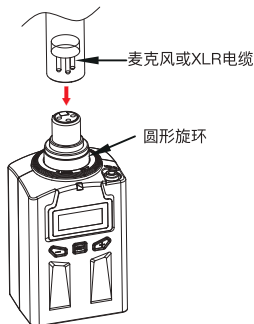



4. 按坚箭头方向旋转卡依母座的旋钮，锁紧麦克风。

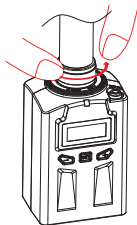

5. 按坚箭头方插入音频端子。

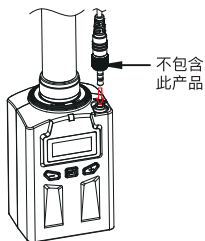

6. 按坚箭头方向旋转螺母，锁紧端子。

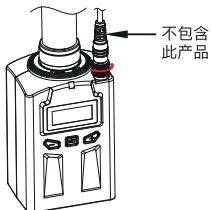

BY-WHM8 PRO  
手持麦克风

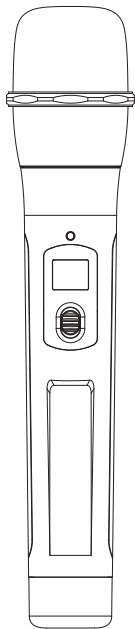

BY-WHM8 PRO可提供宽频率范围并覆盖48个无线通道，它是一款手持式无线话筒发射机。设有一个人体工学机身，易于阅读的液晶显示屏，射频电源开关和晶体控制锁相环合成器。广播级的麦克风将捉清澈和丰富的声音。它有一个内置天线，有噪音抑制功能和电源锁定功能。

## 产品结构

1. 指示灯
2. 显示屏
3. 电源开关
4. 频道切换键
5. 使用2节5号AA电池
6. 电池盖

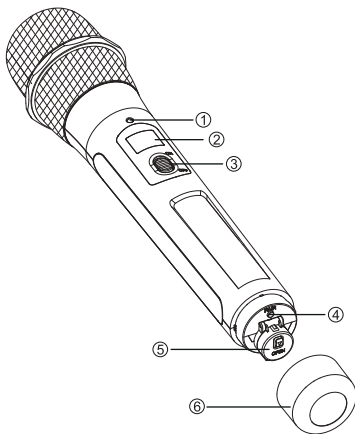

## 安装配置

1. 按箭头方向旋转拧下底盖。

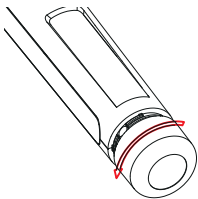

2. 按箭头方向推动按键，  
旋转打开电池仓盖。

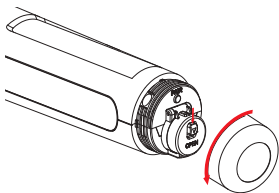

3. 如图装入2节AA电池，  
关上电池仓盖。

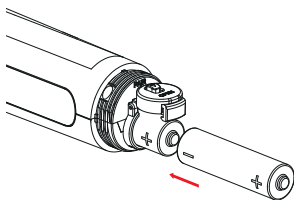

# RX-XLR8 Pro

卡侬无线接收器

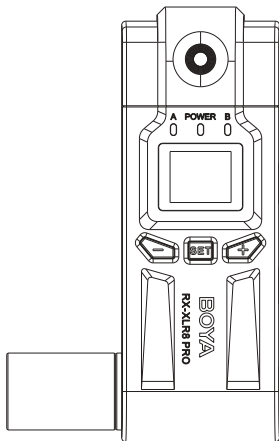

## 产品结构

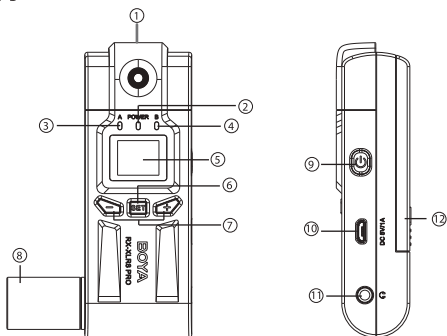

1. 天线
2. LED指示灯

情况	接收器指示灯	发射器A	发射器B
发射器和接收器连接	ANT-A和ANT-B均亮蓝光	亮蓝光	亮蓝光
发射器A和接收器连接; 发射器B和接收器断开连接。	ANT-A亮蓝光; ANT-B关闭	亮蓝光	/
发射器A和接收器断开; 发射器B和接收器连接。	ANT-A灯关闭; ANT-B亮蓝光	/	亮蓝光
发射器和接收器断开连接	ANT-A和ANT-B均关闭	亮蓝光	亮蓝光

3. A通道指示灯
4. B通道指示灯
5. LCD屏幕  
详情请参照“LCD屏幕操作指示”

6. SET按键
7. +/-按键  
调整各数值设定

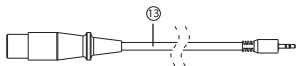

8. XLR输出孔  
连接至摄像机，混音器等设备

9. 电源开关键
10. Micro USB (直流电5V/1A)



11. 耳机监听孔  
将耳机插入进行音频监听
12. 电池仓
13. 卡侬母头转3.5mmTRS 音频转接线
14. 麦克风支架

## LCD显示屏操作说明

- ① A通道开关指示状态
- ② B通道开关指示状态
- ③ 电量显示状态

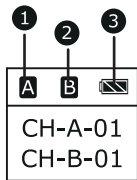

- ④ 通道A
- ⑤ A通道数

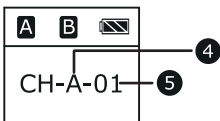

⑥ A通道音量大小 (1-31)

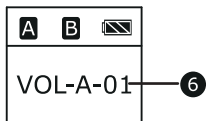

⑦ 通道开启状态 (+/-键调节)



⑧ 通道关闭状态 (+/-键调节)

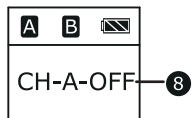

⑨ 通道B

⑩ B通道数

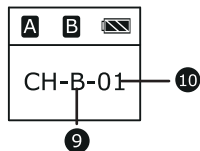

⑪ A通道音量大小 (1-31)

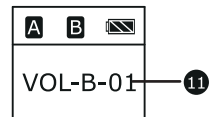



- ⑫ 通道开启状态 (+/-键调节)  
(注意：在连接发射器和接收器的过程中，请先确保通道已处于打开状态)

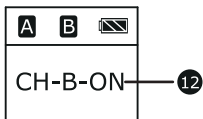

- ⑬ 通道关闭状态 (+/-键调节)

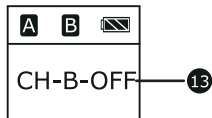

- ⑭ LCD屏幕将自动锁定  
长按“+”和“-”解锁。



## 安装电池

请按照以下步骤安装电池：

1. 移除电池盖，并打开电池仓。
2. 将两节新的AA五号电池放入电池仓内  
请按照正负极指示，正确摆放好电池位置，并关闭电池仓。

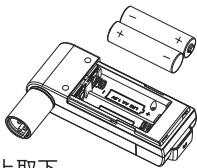
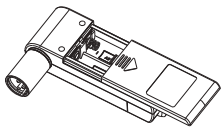

注意：

1. 请确保麦克风处于关闭状态的，因为在信号传输过程中，更换电池可能会引起高噪音。
2. 若长期不使用设备，请将电池从接收器上取下。  
请勿在设备使用过程中更换电池。

## 与相机，摄影机，录音机，和其他录音及摄影设备连接的情况

1. 将配件安装至相机冷靴座，与相机，摄影机，录音机，和其他录音及摄影设备连接。
2. 插入3.5mmTRS音频线至相机的麦克风输入孔。
3. 如果需要监听录制效果，将耳机插入接收器的监听孔。
4. 开启设备，开始录制（电源灯闪蓝光）。
  - 请确保接收器天线朝上，以获得最佳的传输信号。

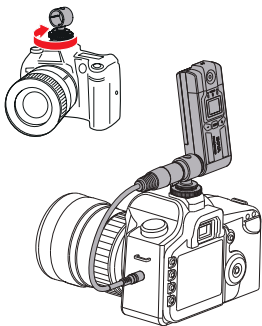

## 与摄像机和其他XLR录音设备一起使用接收器

1. 插入接收器到摄像机和其他XLR音频/视频带有XLR输出的记录设备。
2. 如果需要监听录制效果，将耳机插入接收器的监听孔。
3. 长按电源键开启设备(LED指示灯亮蓝色)
  - 请确保接收器天线朝上，以获得最佳的传输信号。

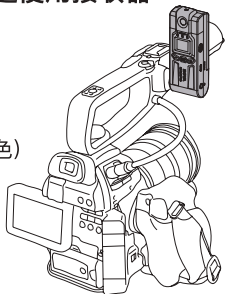

## 注意事项

有关电池的注意事项：

方式不对会导致电池渗漏或者爆炸，必须遵循以下几点：

- 1: 请确保电池极性放置方向是正确的
- 2: 更换电池最好是两节一起替换
- 3: 请勿使用不同品牌的电池作为组合或者一节新电池，一节旧电池这样的组合
- 4: 长时间不使用设备的时候，记得取出电池仓内的电池，以免电池渗漏之后影响设备；如果存在电池渗漏了请及时清除设备以及零部件内的渗漏物。

## 重要提醒

设备用法和存放

- 1: 在电气设备（马达，变压器，调光器）附近操作使用BY-WM8的时候，可能会受到电气设备的电磁感应影响。所以在使用这套麦克风组件的时候尽量远离这些设备。
- 2: 照明灯设备在整个频率范围之内可能会发出电磁干扰，所以要把BY-WM8在合适的地点，降低外界的电磁干扰。
- 3: 为了不影响麦克风的信噪比，尽量不要在嘈杂环境下使用麦克风。比如以下会引起震动的环境：
  - A: 电气设备附近，例如马达，变压器，调光灯等设备
  - B: 空调设备附近或者受空调直接气流影响的地方
  - C: 大声喧闹的公共场合
  - D: 接收机周边存在会有对其产生撞击的物体所以尽量让麦克风远离以上设备位置或者使用其它有效的减震措施

清洁方法：使用干的软布擦拭机器表面和连接处，切勿使用稀释剂清洁，例如：苯，酒精等化学剂，否则有可能会损坏设备。

## 故障排除

如果您在使用BY-WM8 Pro组件时遇到任何问题，请使用以下清单。如果仍有问题，请咨询当地经销商，或与我们联系。

状态	原因	措施
无法开机	电池舱中电池的极性方向不正确。	纠正电池的极性方向
	电池没有电量	更换新的电池
	发射器中的电池端子脏了	用棉签清洗+、-两极端子
电池即将耗尽	电池已经用完了	更换新的电池
	正在使用锰电池	使用碱性电池 锰电池的电池寿命不到碱性电池的一半
	在寒冷条件下使用WM8 PRO系统	电池在寒冷条件下耗电比正常条件要高
频道不能更改	仅通过按下SET按钮无法更改更改频道	重新启动，然后用“+”和“-”按钮更改频道设置
没有声音	发射机上的频道与接收机上的频道不同	将发射器和接收器设置成相同的频道
声音太小	接收器设置的音量太小	调整音量，目标是在整个信号路径中传输最高级别而不失真，以获得最佳信噪比
	误插入到发射器的信号输入的插孔了	从LINE IN中拔出，插到麦克风插口
声音失真	接收器设置的音量不合适	调整音量，目标是在整个信号路径中传输最高级别而不失真，以获得最佳信噪比
	发射器和接收器设置为不同的频道	将发射器设置为相同的频道
	使用了单声道的迷你插孔的耳机	使用立体声的微型插孔的耳机。

<p>声音嘈杂或失真，包括电流声，底噪声，爆音等。</p>	<p>信号被干扰</p>	<ol style="list-style-type: none"> <li>1.尝试切换不同的频道，确保接收和发射在同一个频道上。</li> <li>2.试着把天线定位成45°的角度。室外会有较多的射频干扰。</li> <li>3.试着在室内录制，室内有更少的射频干扰。</li> <li>4.保持发射器在接收器的至少0.6m之外，远离导电物体如金属和水。</li> <li>5.架空的电话线、荧光灯和金属栅栏都会对无线麦克风造成干扰。</li> <li>6.关闭附近的所有电脑和手机。</li> </ol>
<p>声音嘈杂或失真，包括电流声，底噪声，爆音等。</p>	<p>射频信号弱</p>	<p>确保发射器和接收器天线之间的视线畅通无阻。 您的身体、衣服和舞台布景都可能造成阻碍。确保发射器在接收器的100米范围内。 如果有障碍物，您可能需要缩短发射器与接收器的距离。</p>
	<p>摄像机，录像机或调音台的输入电平太高。</p>	<p>调低相机或录音设备的音频输入电平。降低接收器上的音频输出电平。调低调音台的增益。如果设备上没有调整或设置的功能，且电平仍然很高，可调整接收器上的麦克风电平。</p>
<p>太多环境音被拾取</p>	<p>当使用像本系统附带的麦克风那样的全向麦克风时，麦克风可能会拾取较多的环境音。</p>	<p>确保麦克风尽可能靠近被拍摄对象。</p>

## FCC声明：

本设备符合FCC规则的第15部分。

操作符合以下两个条件：

- (1) 本设备不会产生有害干扰。
- (2) 此设备须接受任何收到的干扰，包括可能导致意外操作的干扰。

警告：只有合格的维修人员才可以安装或修理本设备。

注意：“本设备已经过测试，符合FCC规则第15部分对B类数字设备的要求。

这些限制旨在提供合理的防护，防止住宅安装中的有害干扰。本设备会产生辐射射频，如果不按照说明进行安装和使用，可能会对无线电通信造成干扰。

但是，无法保证在特定安装中不会发生干扰。如果此设备确实对无线电或电视接收产生干扰（可通过关闭和打开设备来确定），建议用户尝试通过以下一种或多种措施纠正干扰：

- 1.重新调整或摆放接收天线。
- 2.增加被干扰设备和接收器之间的距离。
- 3.将被干扰设备调整成与接收器的无线电波不一样的频段上。
- 4.请咨询经销商或有经验的无线电/电视技术人员以获取帮助。

## 产品规格:

### 系统

振荡器类型:	PLL合成控制振荡器
载波频率范围:	556.71 MHz–575.98 MHz (发射机A) 576.39 MHz–595.66 MHz (发射机B)
频道数	48
频率响应:	40 Hz t至18 kHz (+/-3dB)
工作温度:	-10°C 至 +50°C( 14° F 至122° F )
储存温度:	-10°C 至 +55°C (14° F 至 131° F )

### TX8 PRO , BY-WXLR8 PRO, BY-WHM8 PRO, RX-XLR8 PRO

射频输出功率	≤10 mW
天线	1 /4λ线天线
杂散发射	250nW或更低
音频输入接口	3.5毫米接口
参考音频输入电平	-60 dBV (MIC输入, 0 dB衰减)
参考偏差	±5 kHz (-60 dBV, 1 kHz输入)
输入频率范围	20Hz–20KHz
失真	0.5%或更少
电源	两节AA电池 两节AA五号电池或Micro USB接口供电(直流电5V)
外形尺寸	TX8 PRO: 20.8x6.7x2.9cm BY-WXLR8 PRO: 5.7x4.55x11.69cm BY-WHM8 PRO: 5.3x5.3x25.6cm RX-XLR8 PRO: 10.74x6.74x2.68cm
重量	TX8 PRO: 81g (不带电池) BY-WXLR8 PRO: 162g (不含电池) BY-WHM8 PRO: 252g (不含电池) RX-XLR8 PRO: 73g (不含电池)

## 接收器参数

音频输出接口：	标准3.5mm接口 RX-XLR8 PRO: XLR音频输出
信噪比：	80db
失真：	0.5%或更少
耳机输出电平：	30mW,32欧姆/1KHz
音频输出电平：	-60 dBV
电源：	2节AA电池，使用时间约6小时（未含）
尺寸：	20.8 × 6.7 × 2.9cm
重量：	95g

## 领夹麦克风参数

传感器：	后驻极体冷凝器
频率范围：	35Hz-18KHz
信号/噪音：	74db SPL
接口：	标准3.5mm迷你插头
麦克风指向性：	全向型
频率范围：	35Hz-18KHz
灵敏度：	-30dB+/-3dB/0dB=1V/Pa, 1KHz
线长：	1.2M



# 频率图表

## 发射器A

频道 (CH)	频率 (MHz)	频道 (CH)	频率 (MHz)
1	556.710	25	566.550
2	557.120	26	566.960
3	557.530	27	567.370
4	557.940	28	567.780
5	558.350	29	568.190
6	558.760	30	568.600
7	559.170	31	569.010
8	559.580	32	569.420
9	559.990	33	569.830
10	560.400	34	570.240
11	560.810	35	570.650
12	561.220	36	571.060
13	561.630	37	571.470
14	562.040	38	571.880
15	562.450	39	572.290
16	562.860	40	572.700
17	563.270	41	573.110
18	563.680	42	573.520
19	564.090	43	573.930
20	564.500	44	574.340
21	564.910	45	574.750
22	565.320	46	575.160
23	565.730	47	575.570
24	566.140	48	575.980

## 发射器B

频道 (CH)	频率 (MHz)	频道 (CH)	频率 (MHz)
1	576.390	25	586.230
2	576.800	26	586.640
3	577.210	27	587.050
4	577.620	28	587.460
5	578.030	29	587.870
6	578.440	30	588.280
7	578.850	31	588.690
8	579.260	32	589.100
9	579.670	33	589.510
10	580.080	34	589.920
11	580.490	35	590.330
12	580.900	36	590.740
13	581.310	37	591.150
14	581.720	38	591.560
15	582.130	39	591.970
16	582.540	40	592.380
17	582.950	41	592.790
18	583.360	42	593.200
19	583.770	43	593.610
20	584.180	44	594.020
21	584.590	45	594.430
22	585.000	46	594.840
23	585.410	47	595.250
24	585.820	48	595.660

[www.boya-mic.com](http://www.boya-mic.com)

**SHENZHEN JIAYZ PHOTO INDUSTRIAL., LTD.**

The BOYA logo is a trademark which is registered and owned by Shenzhen Jiayz Photo Industrial., Ltd.

深圳市长丰影像器材有限公司

地址: 广东省深圳市龙华区观澜街道大富社区硅谷动力智能终端产业园A16栋

TEL: 400 6131096

Email: [sales@boya-mic.com](mailto:sales@boya-mic.com)

[www.boya-mic.com](http://www.boya-mic.com) / [www.jiayz.com](http://www.jiayz.com)